

EIGHT POINT GIBBING

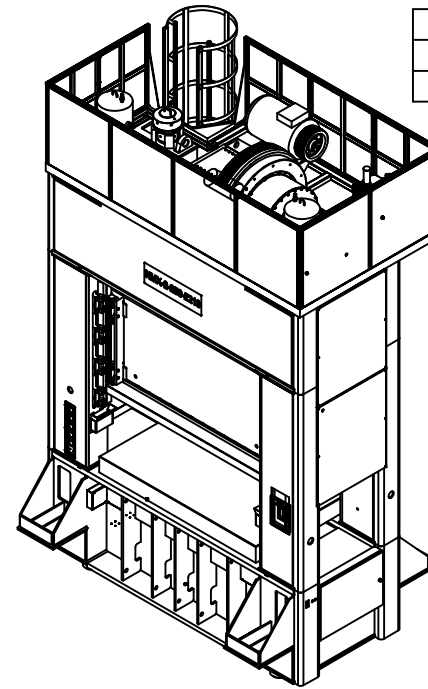
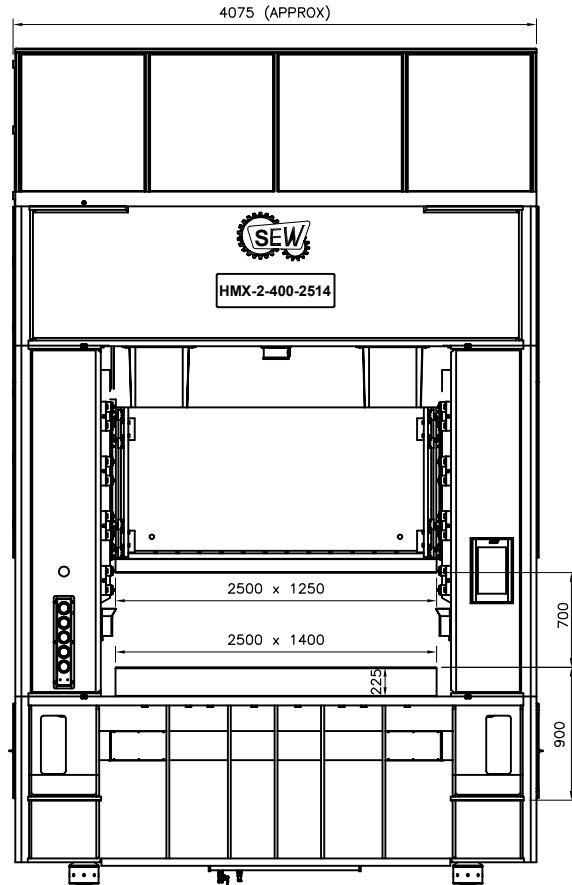
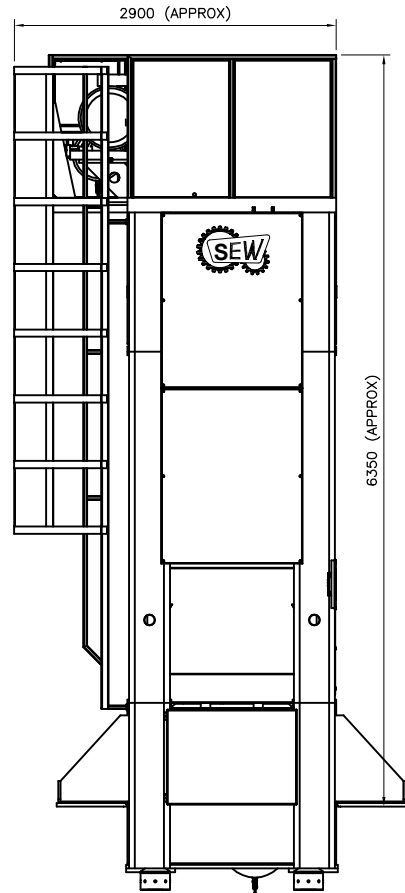

**SEW SPECIFICATION OF HMX-2-400**

DESCRIPTION		
PRESS FORCE CAPACITY @ 6.5 mm FBOS	kN(t)	4000(400)
NUMBER OF SUSPENSION	—	2
STROKE LENGTH	mm	250
STROKE PER MINUTE (VARIABLE)	spm	25-50
SHUT HEIGHT(SDAU)(MAX DIE HEIGHT)	mm	700
SLIDE ADJUSTMENT	mm	150
BOLSTER AREA (LRXFB)	mm	2500x1400
SLIDE AREA (LRXFB)	mm	2500x1250
SIDE OPENING (FBxH)	mm	850x700
SLIDE GUIDING	—	8 POINT FLAT
MAIN MOTOR	kW	55x4P
FLOOR TO TOP OF BOLSTER (W/O PAD)	mm	900
PRESS ACCORDING ACCURACY	—	JIS 6402-1985 GRADE-1
DRIVE	—	CENTRAL GEAR BOX
LUBRICATION	—	CENTRALIZED RECIRCULATING OIL

DIE CUSHION OPTIONAL

CAPACITY	kN(t)	20x2 - 40
STROKE	mm	150
PAD AREA (LRxFB)	mm	900x600x2

DRAWN BY DP CHECKED BY VR APPROVED BY VR DATE 13/01/2020



DRG. NO. GA-HMX-2-400-250-08 SHEET 1 OF 1

NOTE:-DIMENSIONS AND SKETCHES ARE FOR REFERENCE ONLY