

SEW SPECIFICATION OF SCL-2-500-H (CRANKLESS DRIVE)		
DESCRIPTION	UNIT	
CAPACITY	T	500
RATING POINT	mm	13
NUMBER OF SUSPENSION	—	2
STROKE LENGTH	mm	600
CONTINUOUS SPEED (VARIABLE)	spm	10-20
MAX DIE HEIGHT (SDAU)	mm	850
SLIDE ADJUSTMENT (MOTORIZED)	mm	300
BOLSTER AREA (LRXFB)	mm	2500x1600
SLIDE AREA (LRXFB)	mm	2500x1600
SLIDE GUIDING	—	8
MAIN MOTOR	kW	55
FLOOR TO TOP OF BOLSTER	mm	600
PRESS ACCORDING ACCURACY	—	JIS 6402-1985 GRADE-1
DRIVE	—	ECCENTRIC GEAR
LUBRICATION	—	CENTRALIZED RECIRCULATING OIL
BOLSTER THICKNESS	mm	235

DIE CUSHION (PISTON TYPE)		
DESCRIPTION	UNIT	
CAPACITY	tone	80
STROKE	mm	160
PAD AREA	mm	2050x1150

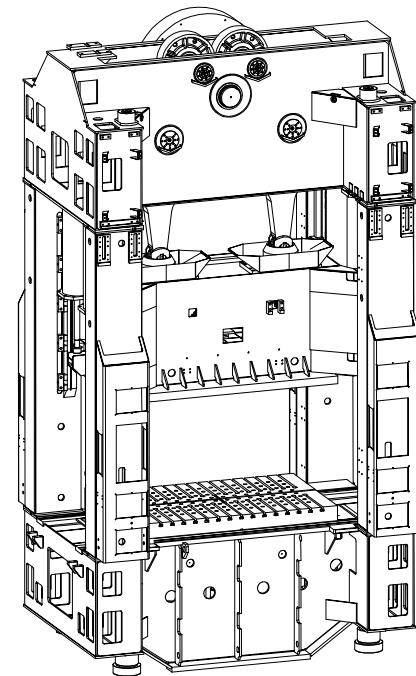

SEW SINGHAL
POWER PRESSES PVT.LTD

DRAWN BY	PRITESH
CHECKED BY	
APPROVED BY	VR
DATE	12/01/2020