

8-POINT GIB

SEW SPECIFICATION OF SCL-2-500-M (CRANKLESS DRIVE)		
DESCRIPTION	UNIT	
CAPACITY	T	500
RATING POINT	mm	13
NUMBER OF SUSPENSION	—	2
STROKE LENGTH	mm	400
CONTINUOUS SPEED (VARIABLE)	spm	12-25
MAX DIE HEIGHT (SDAU)	mm	850
SLIDE ADJUSTMENT (MOTORIZED)	mm	200
BOLSTER AREA (LRXFB)	mm	2500x1300
SLIDE AREA (LRXFB)	mm	2500x1300
SLIDE GUIDING	—	8
MAIN MOTOR	kW	55
FLOOR TO TOP OF BOLSTER	mm	600
PRESS ACCORDING ACCURACY	—	JIS 6402-1985 GRADE-1
DRIVE	—	ECCENTRIC GEAR
LUBRICATION	—	CENTRALIZED RECIRCULATING OIL
BOLSTER THICKNESS	mm	235

DIE CUSHION (PISTON TYPE)		
DESCRIPTION	UNIT	
CAPACITY	tone	80
STROKE	mm	160
PAD AREA	mm	2050x1150

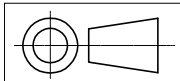
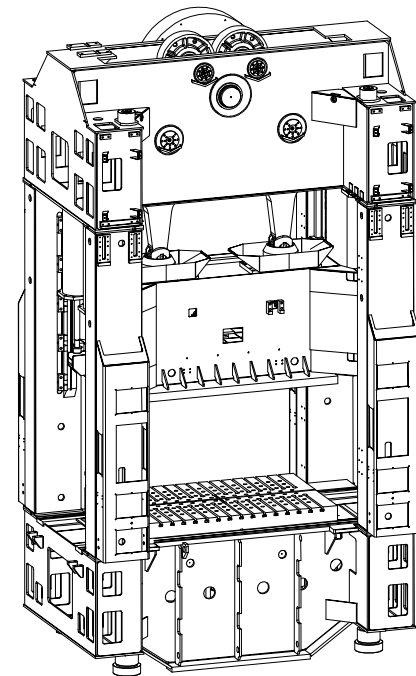

TITLE	G.A.DRAWING	DRG. NO.	SCL-2-500-M-08	REV.	00
-------	-------------	----------	----------------	------	----

SEW SINGHAL POWER PRESSES PVT.LTD	
DRAWN BY	PRITESH
CHECKED BY	
APPROVED BY	VR
DATE	12/01/2020