

EIGHT POINT GUIDEWAYS

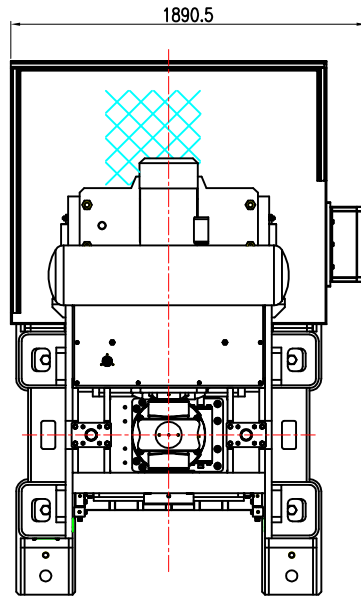

APPROX. 1597

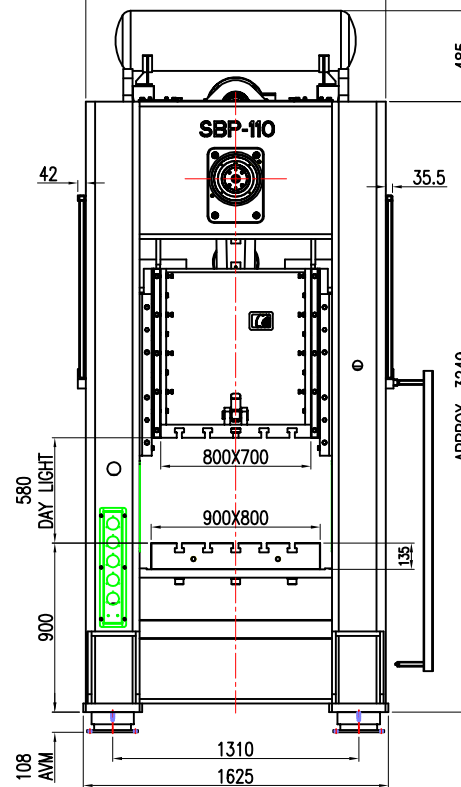

108
AVM

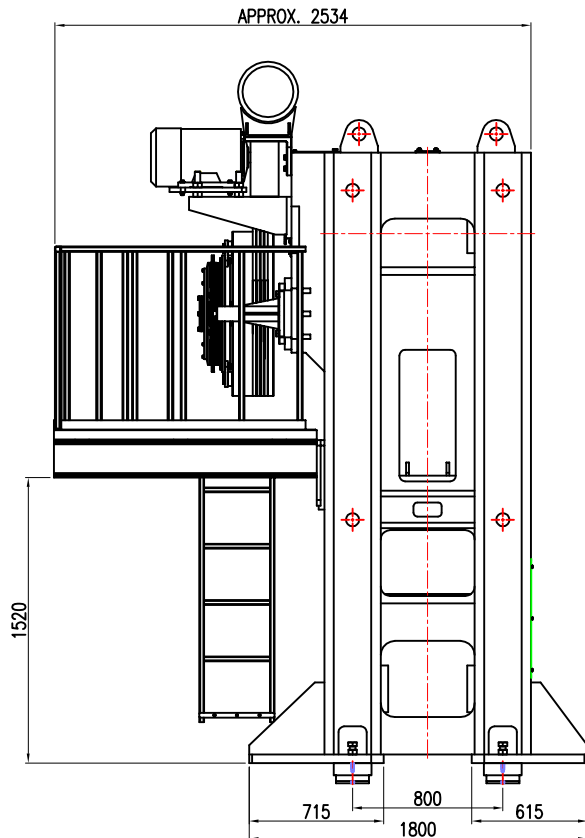

APPROX. 2534

SPECIFICATION OF SBP-110 SG [GEARED]

PRESS CAPACITY IN TON	110 Ton (1100 KN)
STROKE LENGTH (FIX)	180 mm
TONNAGE RATING POINT [B.D.C]	5 mm
SLIDE ADJUSTMENT	90 mm
SLIDE AREA [LRxFB]	800x700 mm
DIE HEIGHT [SDAU]	400 mm
BOLSTER AREA [LRxFB]	900x800 mm
BOLSTER THICKNESS	135 mm
MACHINE SPEED [FIX]	50 SPM
MACHINE SPEED [VARIABLE]	35~60 SPM
MAIN MOTOR FOR FIX SPEED	15 hp
MAIN MOTOR FOR VARIABLE SPEED	20 hp
FLOOR TO TOP OF BOLSTER	900 mm (W/O AVM)
OVER LOAD SAFETY	HYD. OVER LOAD
LUBRICATION (GREASE)	MOTORIZED
CAM LIMIT SWITCH	ENCODER BASED E-CAM

PNEUMATIC DIE CUSHION -OPTIONAL ACCESSORIES

PNEUMATIC DIE CUSHION (BELLOW TYPE)	8 TON
PNEUMATIC DIE CUSHION STROKE (FIXED)	90 mm
PNEUMATIC DIE CUSHION PAD AREA	480 X 300mm

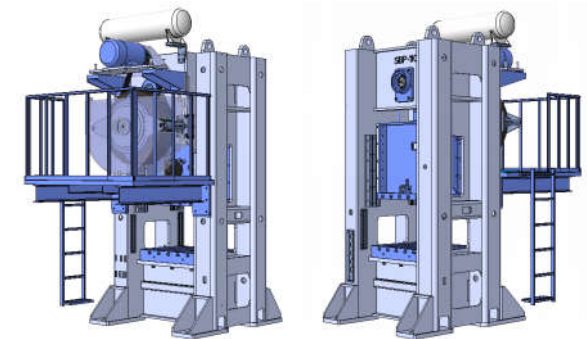

SCALE	1:1	SURFACE FINISH	WEIGHT
DATE	15/01/2024		12.5 TON
DRAWN	DK	MATERIAL:	
CHKD.	DK		
APPD.	MS		

PROJECTION	NAME:
	G.A DRAWING-SG
	DRG.NO.
	SBP-110 -08



SINGHAL
POWER PRESSES PVT.LTD

