

SPECIFICATION OF SNX-2-110 SG MODEL

CAPACITY IN TON	110 (1100 KN)
NO. OF SUSPENSION	2
STROKE LENGTH (FIXED)	180 mm
SPEED (FIX SPM)	50 SPM
SPEED (VARIABLE SPM)	35~65 SPM
DRIVE	GEARED
TONAGE RATING POINT(B.D.C.)	5 mm
SHUT HEIGHT FROM BOLSTER	400 mm
SLIDE ADJUSTMENT (MOTORIZED)	90 mm
BOLSTER AREA	1880 X 680 mm
BOLSTER THICKNESS	145 mm
SLIDE AREA	1430 X 520 mm
MAIN MOTOR (FIX SPM)	10 hp
MAIN MOTOR (VARIABLE SPM)	15 hp
FLOOR TO TOP OF BOLSTER	1000 mm
LUBRICATION	MOTORISED GREASE

OPTIONAL ACCESSORIES - DIE CUSHION

CAPACITY	6 TON X 2
DIE CUSHION STROKE LENGTH	70 mm
DIE CUSHION PAD AREA	960 X 340

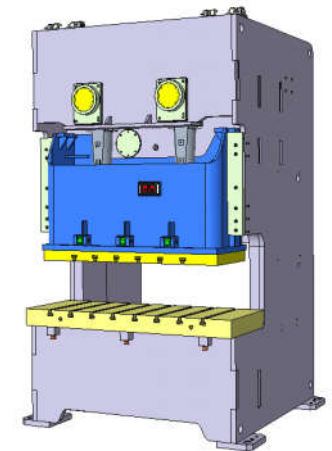

SIX POINT GIBBING

LINEAR DEVIATIONS WHERE NOT SPECIFIED								ANGULAR DEVIATIONS WHERE NOT SPECIFIED					
LENGTH mm	≤6	≤30	≤120	≤315	≤1000	≤2000	≤4000	≤8000	LENGTH mm SHORTER SIDE OF ANGLE	≤6	≤30	≤120	≤400
TOL.± mm	0.1	0.2	0.3	0.5	0.8	1.2	2	3	TOL. ON ANGLE ± DEG. / MIN.	1'	30'	20'	10'

REV.	DESCRIPTION	SIGN	DATE	PROJECTION	NAME:	G.A DRAWING-SG
				MODEL: SNX-2-110 SG	QTY	
				SCALE 1:1	SURFACE FINISH	WEIGHT
				DATE 15/01/2024		18 TON
				DRAWN DK	MATERIAL:	
				CHKD. DK		
				APPD. MS		
				DRG.NO.	SNX-2-110-8 HG	



**SINGHAL**  
POWER PRESSES PVT.LTD



NAME: G.A DRAWING-SG  
DRG.NO. SNX-2-110-8 HG